

11A Where are you travelling to?

Activity type: Speaking and listening – Role play – Pairs

Aim: To practise using the language of airports and flying

Language: Airports – Use at any point from 11.1.

Preparation: Make one copy of both worksheets for every two learners. Cut up cards a–h on worksheet 1 along the dotted lines.

Time: 25 minutes

- 1 Divide learners into pairs. Give each pair a copy of the top half of worksheet 1.
- 2 Ask learners to look at the picture and the gapped dialogue in the box, and try to identify the situation: *an airport check-in desk*.
- 3 Learners work in pairs and try to fill in the missing parts of the dialogue. They should write their ideas on the lines.
- 4 When they have finished, give each pair a set of cards a–h. They match the cards with the lines in the dialogue. When they have finished, check their answers and discuss any differences between the answers and their own ideas.

1 e 2 g 3 d 4 b 5 a 6 f 7 c 8 h

- 5 Learners practise acting out the dialogue with their partner, taking it in turn to play the roles of passenger and check-in attendant.
- 6 Give each pair a copy of worksheet 2. Learners look at the boxes and pictures, representing different check-in scenarios. They work in pairs to match the pictures with the information in boxes.

1 c 2 b 3 d 4 e 5 f 6 a

- 7 Learners take it in turn to be the passenger and the check-in attendant and to act out new dialogues, with the passenger using the prompts in the boxes. Explain that any combinations are possible (e.g. a passenger might be flying to New York with a suitcase and a bicycle, and a briefcase as hand luggage). They practise their dialogues until they are able to recite them without reading from the script, if possible.
- 8 Ask each pair to act out a dialogue for the class. Other learners should listen and in each case note down the passenger's destination, the luggage they wish to check in, and the hand luggage they wish to take on the plane with them. When each pair has acted out their scenario, check that other learners have correctly identified these details.

11A Where are you travelling to? 1



A: Next please ... Good morning.

B: *Good morning.*

A: ¹ _____, please?

B: *I'm going to London.*

A: OK. ² _____, please?

B: *Here you are.*

A: Thanks. ³ _____, please?

B: *Yes, of course.*

A: Is it just the one suitcase?

B: *Yes, just the one.*

A: OK. ⁴ _____ ?

B: *Yes, I did.*

A: And ⁵ _____ ?

B: *No, I'm not.*

A: OK. ⁶ _____ ?

B: *Just this bag.*

A: OK, that's fine. ⁷ _____ .

B: *Thank you.*

A: Your plane leaves from Gate 12. ⁸ _____ .

B: *Thanks.*

A: You're welcome. Have a good flight.



<p>a are you carrying anything for anyone else</p>	<p>b Did you pack your suitcase yourself</p>
<p>c Here's your passport, your ticket, and your boarding card</p>	<p>d Can you put your bags on the scales</p>
<p>e Where are you travelling to</p>	<p>f Do you have any hand luggage</p>
<p>g Can I see your passport and ticket</p>	<p>h It'll start boarding in about 45 minutes</p>

11A Where are you travelling to? 2

A

Hong Kong

No, a suitcase and a sports bag.

Yes, I've got my laptop.

B

New York

No, two suitcases actually.

Yes, a small hold-all.

C

Munich

Yes. Oh, and a bicycle.

Yes, a small rucksack.

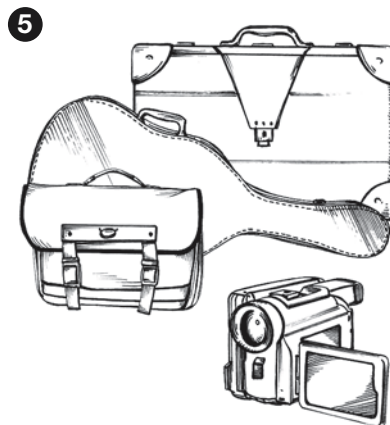
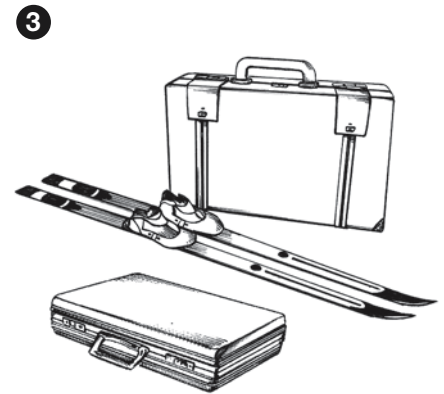

D

Auckland

No, I've also got some skis.

A briefcase.

E

Buenos Aires

No, I've got a golf bag as well.

No. No hand luggage.

F

Tokyo

And this guitar, too.

Yes. This bag, and a camcorder.